



The product shown may differ from standard configuration.



# ROADTIGER® STANDARD

The first steps



# ROADTIGER® STANDARD

## Technical data

### The first steps

The ROADTIGER Standard features a pneumatic suspension system with automatic weight adjustment. It also comes with a fore/aft isolator, lumbar support and a finely adjustable backrest. The seat tilt adjustment and adjustable seat cushion depth ensure ergonomic comfort whilst sitting even in the entry level.



Pneumatic suspension



Pneumatic lumbar support



Automatic weight adjustment



Adjustable shock absorber



Fore/aft isolator

### Features

### ROADTIGER® STANDARD

### ROADTIGER® STANDARD

| PART NUMBERS  |        |           |  |
|---|--------|-----------|--|
| <b>Daimler</b> (left, track gauge 280 mm)               |        | 1439931-A |  |
| <b>Daimler</b> (right, track gauge 280 mm)              |        | 1439932-A |  |
| <b>DAF</b> (left, track gauge 305 mm)                   |        | 1401903-A |  |
| <b>DAF</b> (right, track gauge 305 mm)                  |        | 1401905-A |  |
| STANDARD FEATURES                                       |        |           |  |
| Pneumatic suspension                                    |        | ●         |  |
| <b>1</b> Shock absorber, adjustable in 4 steps          |        | ●         |  |
| Suspension stroke, 55 mm                                |        | ●         |  |
| <b>2</b> Height adjustment, 145 mm                      |        | ●         |  |
| Automatic weight adjustment, 50 up to 190 kg            |        | ●         |  |
| <b>3</b> Fore/aft adjustment Daimler                    | 230 mm |           |  |
| Fore/aft adjustment DAF                                 | 220 mm |           |  |
| <b>4</b> Quick down                                     |        | ●         |  |
| <b>5</b> Fore/aft isolator, 25 mm                       |        | ●         |  |
| <b>6</b> Adjustable seat cushion angle                  |        | ●         |  |
| <b>7</b> Integrated headrest                            |        | ●         |  |
| <b>8</b> Adjustable backrest angle                      |        | ●         |  |
| <b>9</b> Pneumatic lumbar support                       |        | ●         |  |
| <b>10</b> Seat cushion depth adjustment, 60 mm, 6 steps |        | ●         |  |
| <b>11</b> Integrated 3-point belt                       |        | ●         |  |
| Belt buckle with contact switch (only DAF)              |        | ●         |  |
| Seat belt pretensioner (only DAF)                       |        | ●         |  |
| Upholstery fabric                                       |        | ●         |  |
| OPTIONAL FEATURES                                       |        |           |  |
| <b>12</b> Comfortable armrests, tiltable                |        | ○         |  |

### Measurements (installation dimensions)

● STANDARD FEATURES ○ OPTIONAL FEATURES

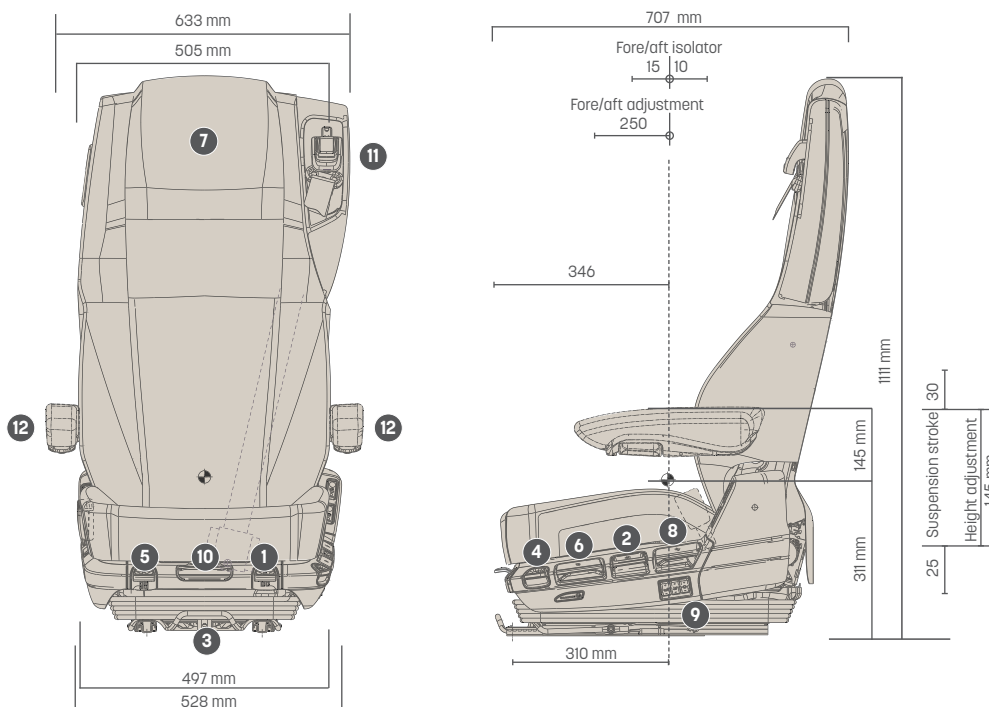

Different track gauges available. All dimensions in mm. Subject to technical changes.