



The product shown may differ from standard configuration.

MSG 20 NARROW

Compact seat with mechanical suspension



MSG 20 NARROW

Technical data

Compact seat

All MSG 20 seats are optimally designed to attenuate the vibrations to which forklift operators are typically subjected, featuring suspension travel of 60 mm. They are also simple to set to any user weight between 50 and 130 kg with an easy-to-use lever on the backrest, resulting in optimal suspension comfort for every operator. In addition, the seat's fore-aft position can be varied by up to 150 mm to provide enough space for every body size and work situation. The narrow version with a cushion width of 410 mm is specially optimized for reach-type forklift trucks.



Mechanical Suspension



Mechanical Weight Adjustment

Features

	MSG 20 NARROW	
ARTICLE NO.		
Fabric	1293151	1293152
Imitation leather	135671	135673
STANDARD FEATURES		
Mechanical suspension	●	●
Suspension stroke, 60 mm	●	●
1 Weight adjustment, 50 - 130 kg	●	●
2 Fore/aft adjustment, 150 mm	●	●
3 Adjustable backrest angle		

	MSG 20 NARROW	
Seat cushion width	410 mm	410 mm
Operator presence switch (OPS)		●
OPTIONAL FEATURES		
Armrests 54 mm x 300 mm, foldable	○	○
Document box	○	○
Restraint system		
Static belt	○	○
Retractor belt	○	○
Seat heating	○	○

Measurements (installation dimensions)

● STANDARD FEATURES ○ OPTIONAL FEATURES

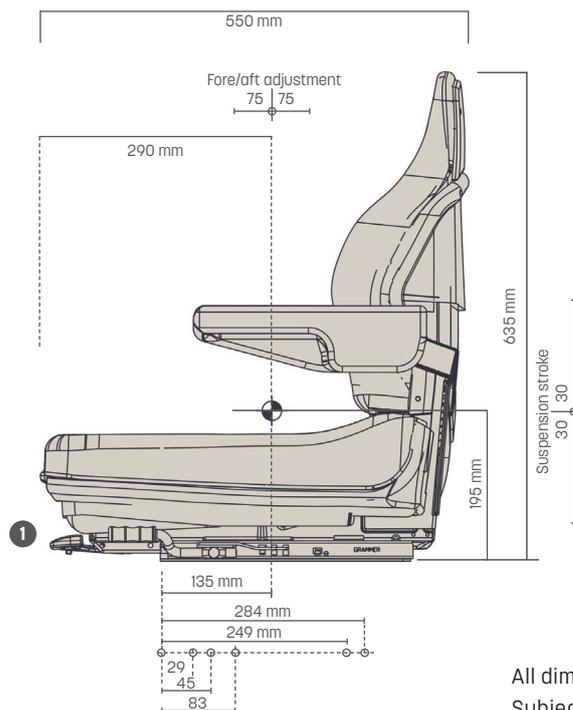
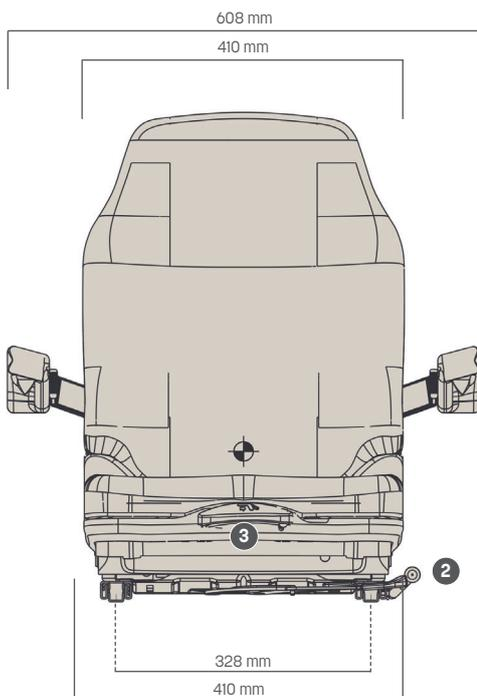

All dimensions in mm.
Subject to technical changes.