



The product shown may differ from standard configuration.

## MSG 20

Compact seat with mechanical suspension



# MSG 20

## Technical data

### Compact seat

All MSG 20 seats are optimally designed to attenuate the vibrations to which forklift operators are typically subjected, featuring suspension travel of 60 mm. They are also simple to set to any user weight between 50 and 130 kg. In addition, the seat's fore-aft position can be varied by 150 mm or 210 mm, depending on the seat version, to provide enough space for every body size and work situation.



### Features

### MSG 20

ARTICLE NO.					
Fabric			1293150		
Imitation leather	134015	141999	142001	143465	1017487
<b>STANDARD FEATURES</b>					
Mechanical suspension	●	●	●	●	●
Suspension stroke, 60 mm	●	●	●	●	●
<b>1</b> Weight adjustment, 50 - 130 kg	●	●	●	●	●
<b>2</b> Fore/aft adjustment, 150 mm		●	●	●	
Fore/aft adjustment, 210 mm	●				●
<b>3</b> Adjustable backrest angle	●	●	●	●	●
<b>4</b> Restraint system					
Duo-sensitive retractable belt		○	○	●	
Belt holder preassembled	●				●
Seat cushion width	470 mm	470 mm	470 mm	470 mm	470 mm
Operator presence switch (OPS)			●	●	●
<b>OPTIONAL FEATURES</b>					
<b>5</b> Armrests, 45 mm x 300 mm, foldable	○	○	○	○	○
<b>6</b> Document box	○	○	○	○	○
Retractor belt	○	○	○		○
Static belt	○	○	○		○
Seat heating	○	○	○	○	○

### Measurements (installation dimensions)

● STANDARD FEATURES ○ OPTIONAL FEATURES

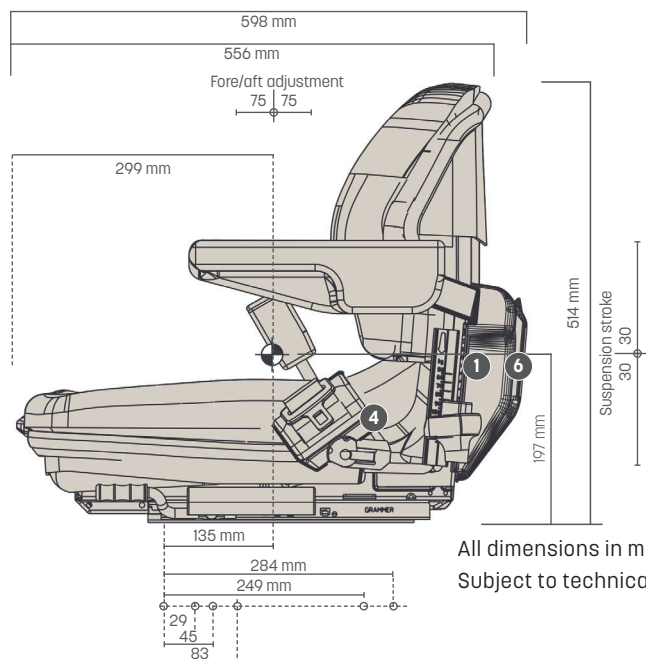
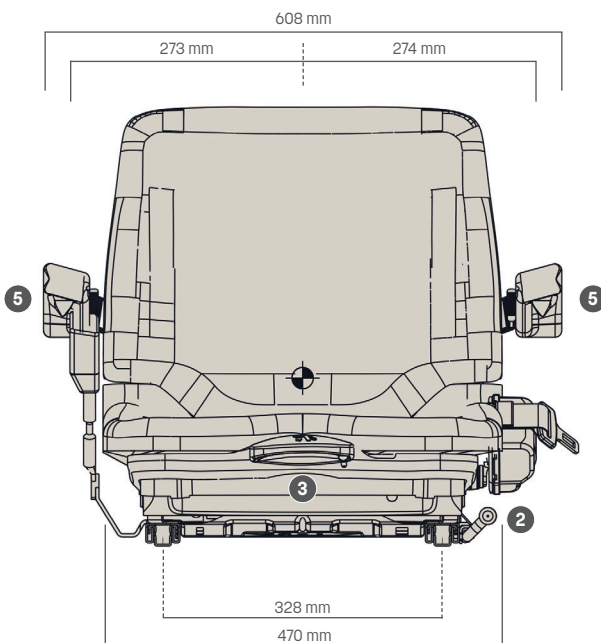

All dimensions in mm.  
Subject to technical changes.